

## Technical Specification

# Rocket Boomer 353ES-1838

Hydraulic drill rig with three BUT 35 booms for cross sections up to 168 m<sup>2</sup>.

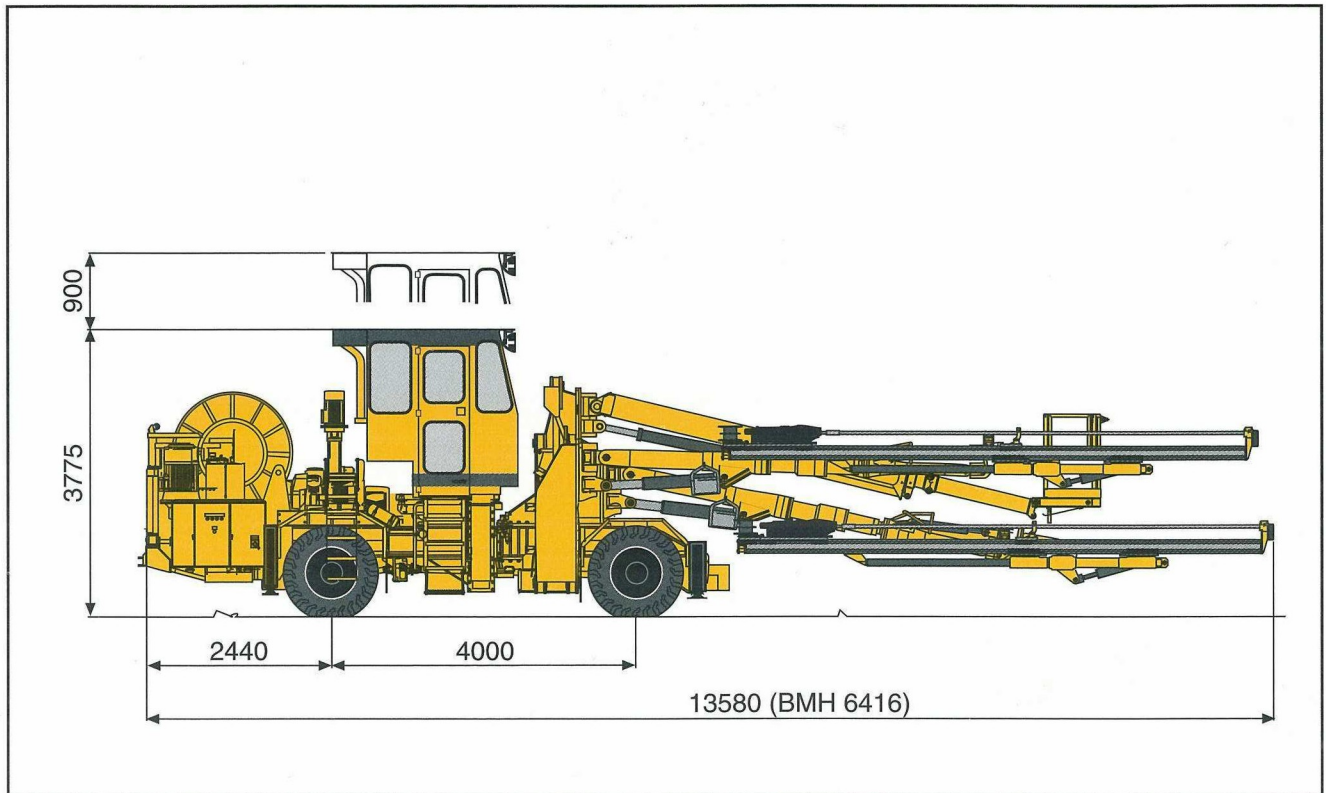
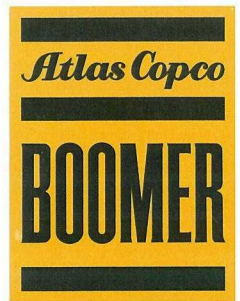

Rocket Boomer 353ES in transport position. During drilling the cabin can be raised. All dimensions in mm.

### Main features

- COP 1838 rock drill with new reflex dampener gives genuine high speed drilling and excellent drill steel economy. New lubrication system with separate lubrication of driver, gear, pressurized sidebolts and mating surfaces gives reliable operation, low maintenance cost and long time between overhauls.
- Extended coverage area of 15.3 m width x 12.6 m height due to 3.5 m swing elevation of outer booms.
- Compact transport width of 2.5 m only.
- BMH 6400 heavy duty aluminium hydraulic feeds with double bottom for high torsional resistance. Snap-on stainless steel sleeves and polymer contact pads for long life and low maintenance costs.
- BUT 35 heavy duty booms with direct, accurate and parallel movement for fast positioning.
- ECS 18-3-55 power efficient drilling system with full control of impact power and feed force, increases drilling capacity and gives outstanding drill steel economy. RPCF (Rotation Pressure Controlled Feed force) and RPCI (Rotation

pressure Controlled Impact power) gives superb anti-jamming function and adjusts feed force and impact power to variations in drilling conditions. Separate pumps for impact, rotation and dampening for independent control and maximum output. Logical, proportional controls with one joystick makes drilling easy and accurate.

- DC 141 sturdy carrier for high mobility and stable set up. The four wheel drive carrier is specially designed for underground mining and tunnelling operations.
- Basic rig includes liftable insulated operator's cab, water booster pump, cable reel and working lights. The cab is spacious, ergonomically designed and FOPS-certified (with a sound level well below 85 dB(A)).

### Main components

Rock drill	3 x COP 1838ME
Feed	3 x BMH 6400-series
Boom	3 x BUT 35
Drilling system	ECS 18-3-55
Carrier	DC 141

## Rock drill COP 1838ME

Drill steel	R 38 or T 38
Height over drill centre	88 mm
Impact power	20 kW
Impact rate	60 Hz
Hydraulic pressure, max.	250 bar
Lub. air consump. (at 3 bar)	5 l/s
Water requirement	1.1 l/s
Rotation system	separate rotation
Rotation speed	0-300 rpm
Rotation torque, max.	500 Nm
Weight	171 kg

## Feeds

	BMH 6414	BMH 6416	BMH 6418	BMH 6420
Total length (mm)	5880	6490	7100	7710
Drill steel length (mm)	4305	4915	5525	6135
Hole depth (mm)	4030	4640	5250	5860
Weight, incl. rock drill (kg)	610	650	680	710
Feed force (kN)	20.0	20.0	20.0	20.0

## Boom BUT 35

Feed extension	1800 mm
Boom extension	1600 mm
Parallel holding	Complete
Feed roll-over	360 degrees
Max. lifting angle	+70 degrees
	-30 degrees
Max. swinging angle	±45 degrees
Weight, boom only	2700 kg

## Drilling system ECS 18-3-55

Control system	electrical, PLC-based
Hydraulic system	3 separate units, one for each boom. Each system consists of one variable pump for percussion and two constant flow pumps for rotation and dampening.
Pump motors	3 x 55 kW
System pressure, impact mechanism	150-250 bar
Hydraulic oil tank, volume	480 litres
Compressor, type	Atlas Copco LE 55
capacity	12.8 l/s (at 6 bar)
Water booster, capacity	300 l/min at 14 bar boost
Minimum water inlet pressure	4 bar

## Carrier

Type	Atlas Copco DC 141
Engine	Deutz BF6M 1013C, water cooled turbocharged 170 kW (231 hp) at 2400 rpm
Max. travel speed	18 km/h
Transmission	Hydrodynamic Clark 32000
Gradeability	1:4 at max. load on drive wheels
Braking system	All hydraulic, with parking and emergency brake
Tyres	12.00 R 24 XKA *** Michelin
Steering system	Power steering

## Atlas Copco hydraulic boom BUT 35.

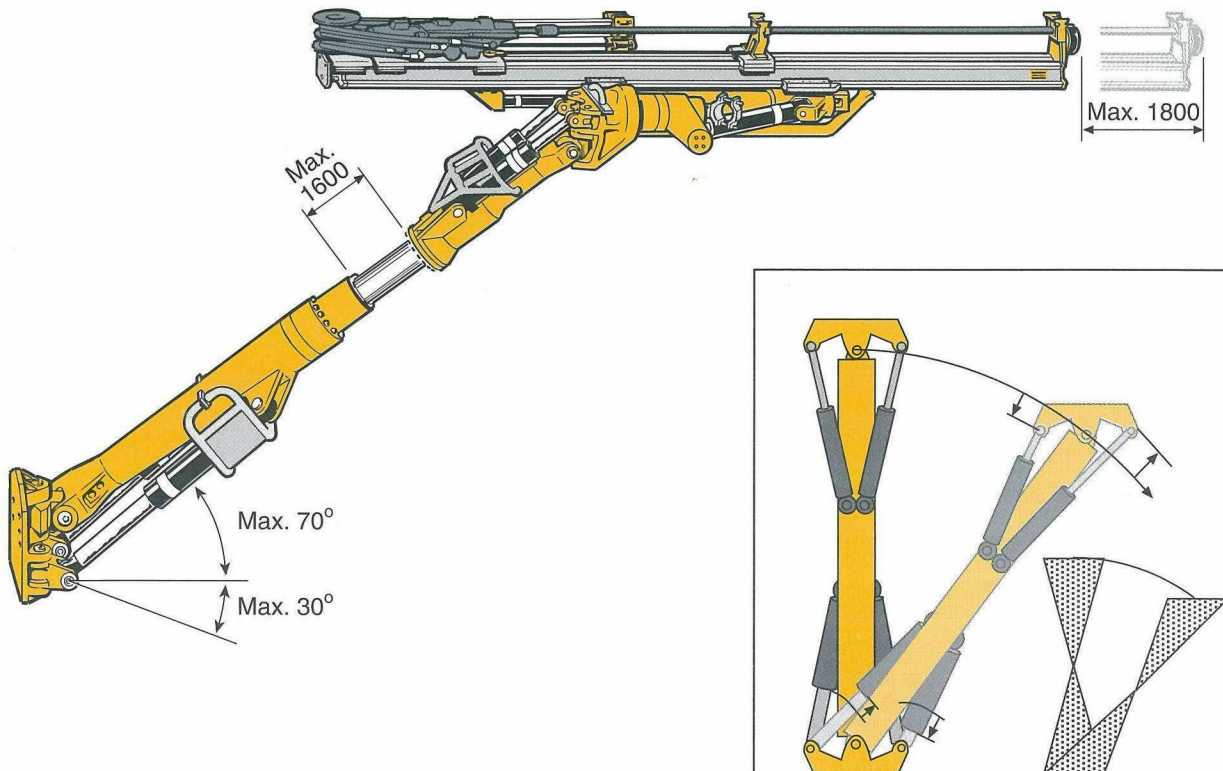

Double tripod suspension gives accurate parallel holding in all directions.

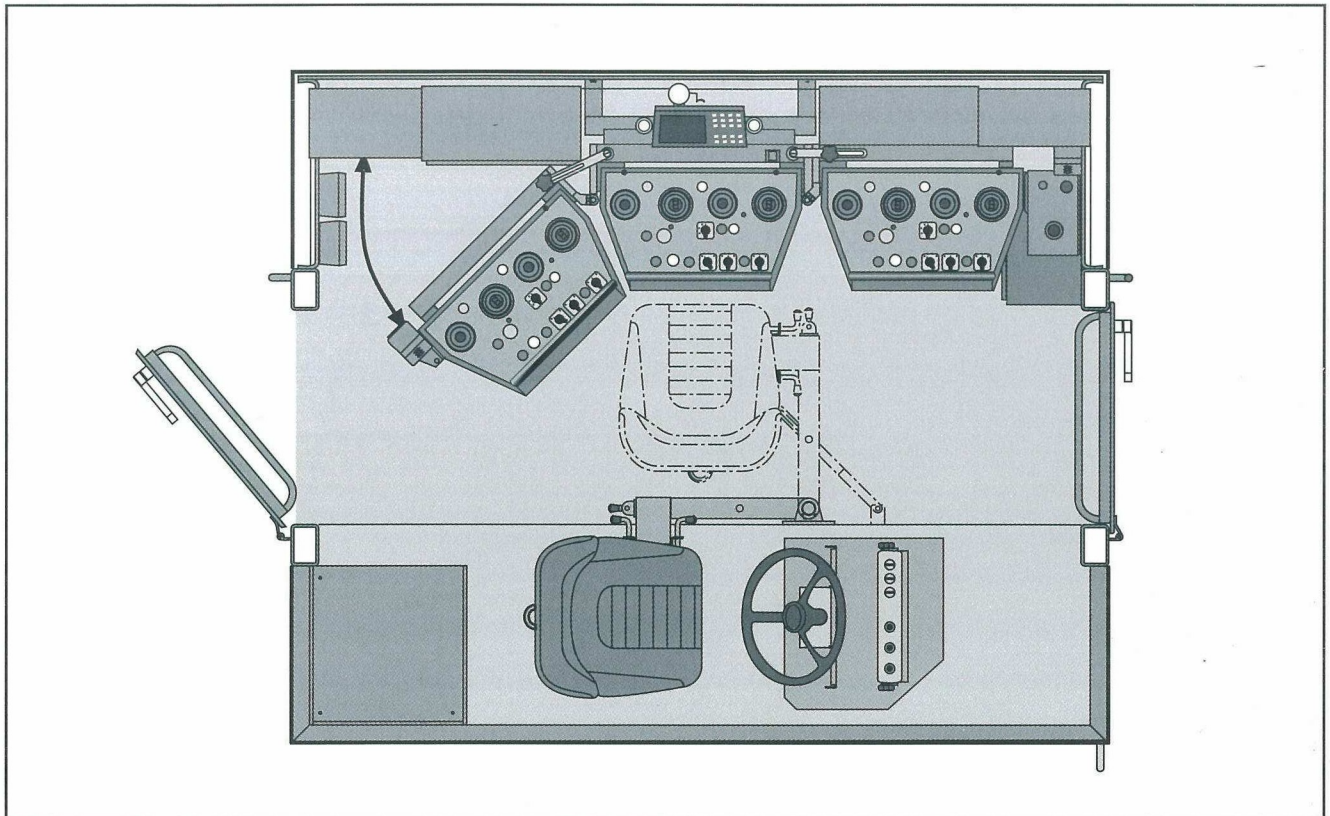

The control panel console can be adjusted vertically. Furthermore the left and right panels can be turned, all in order to permit a perfect working position.

### Ergonomical working station

In the spacious cabin up to three operators can individually control a separate boom at the same time. The operator can choose a standing or sitting working position.

Each boom is equipped with a separate control panel. A complete drilling operation is controlled with one joystick. Two separate joysticks are used to position the boom.

### Electrical system

Total power requirement	190 kW
Voltage (on customers request)	380-1000 V
Frequency	50-60 Hz
Starting method	star/delta

Voltage (V)	Recommended size of cable	Cable reel capacity* (m)
380-440 V	4 x 120 mm <sup>2</sup>	90
500-660 V	4 x 95 mm <sup>2</sup>	110
1000 V	3 x 50 mm <sup>2</sup> and 3 x 10 mm <sup>2</sup>	200

\* = Depending on type of cable.

### Dimensions and weights

Height (min. transport height)	3775 mm
Width	2500 mm
Length (with 16 ft feeds)	13580 mm
Turning radius	outer 10400 mm inner 5650 mm
Gross weight**	42000 kg
Axle load**	boom side 30000 kg engine side 12000 kg

\*\* = Depending on equipment.

### Optional equipment

- 700 mm fixed segment for extended boom reach.
- Electric cable type RDOT.
- Water hose reel including a 60 meter 2" water hose.
- Exhaust scrubber and/or catalyzer.
- Telescopic feed BMHT 6400-series (only for BUT 35 standard booms not for booms with fixed segment extension).
- Rod Adding System, RAS, for extension drilling of extra long holes, using Speedrod extension rods. Max 18 ft RAS on standard BUT 35 booms. Max 16 ft RAS on booms with fixed segment extension.
- BSH 110 drill steel support for extension drilling.
- TAS, feed angle display.
- Bever Data guidance system.
- Automatic boom lubrication system.
- Service platform:
 

<i>Description</i>	<i>Lifting capacity</i>
HL 210-MB	400 kg
HL 230-MB	400 kg
HL 300-MB	600 kg
- Hydraulic Swellex pump.
- Air blowing kit with Atlas Copco LE 11 compressor.
- ANSUL, Fire extinguisher.
- Foam filled tyres.

# Rocket Boomer 353ES-1838

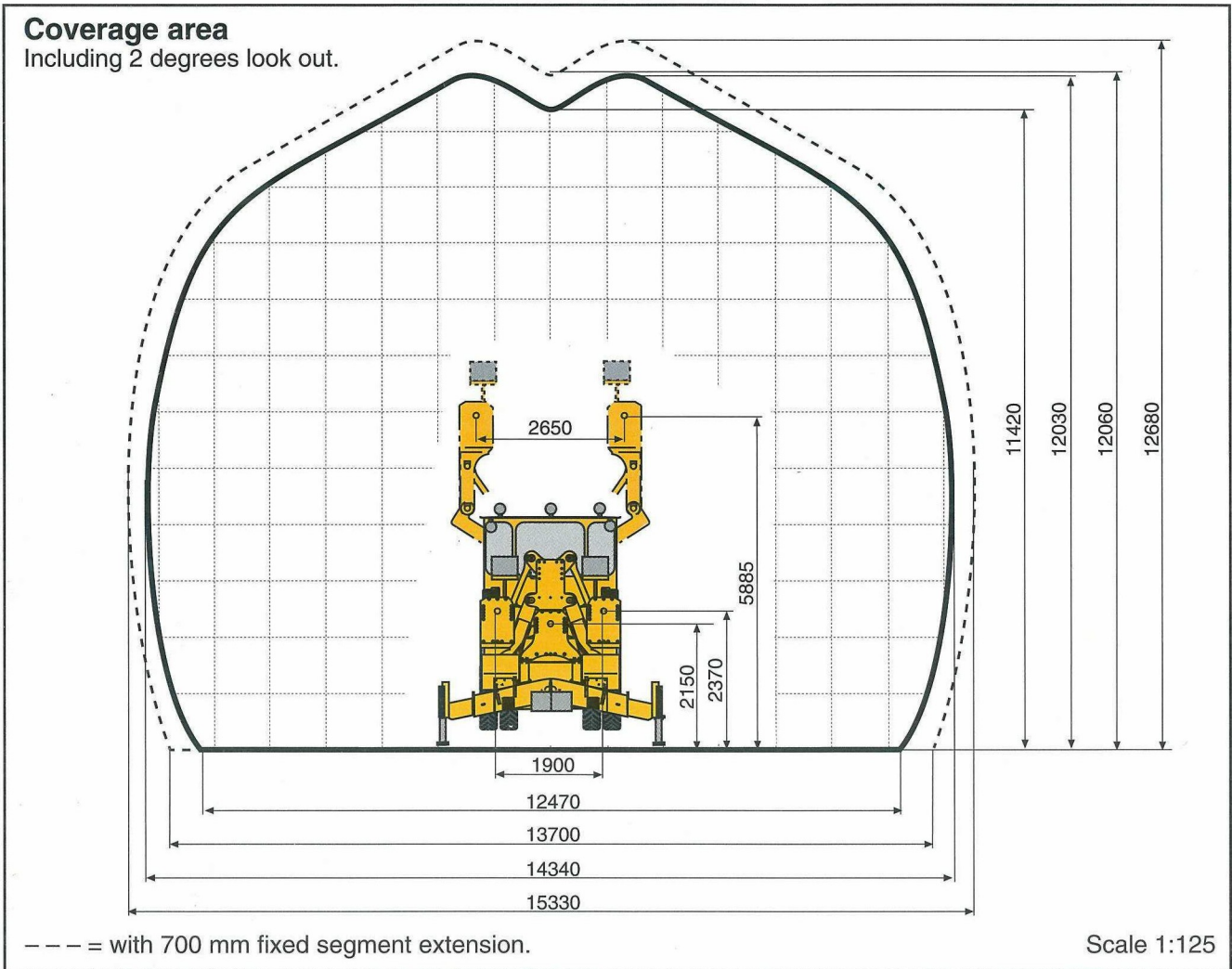

## Rod Adding System, RAS

RAS is a mechanized rod adding system used for drilling of "longer than feed" holes, for example for grouting, investigation or longer drill rounds. It consists of a control unit and two mechanical grippers mounted on the feed beam.

The drilling cycle starts with one SPEEDROD in the feed and another in the grippers. When the first rod is drilled into the rock,

the drill steel support grippers the rod at the coupling end and the rod is uncoupled. The rockdrill reverses after which the second rod is placed on the feed by the grippers. Thereafter the second rod is coupled into the rod already in the hole and the drilling of the hole is continued. Additional extension rods can be loaded manually on the grippers.

## Atlas Copco Rock Tools

### Drifter rods

Dimension	Min. hole dia, mm
T38-Hex 35-R32	45
T38-Hex 35-R32 SPEEDROD	45
R38-Hex 35-R32	45

### Shank adapters

Thread	Dia, mm	Length, mm	Part No.
T38	38	435	7304 3652 01
R38	38	435	7804 3652 01
T38	38	525	7304 3656 01*
R32	38	525	7803 3656 01*

\*= Intended for rod adding system, RAS, and extension drilling.

For other dimensions and more information please see Atlas Copco Rock Tools catalogue, printed matter No. 9851 1622 or Selection Guide for Tunnelling and Drifting, printed matter No. 9851 1637.

### Extension rods for injection drilling/RAS

Dimension	Min. hole dia, mm
T38 SPEEDROD	64
T38-Rd 38-T38	64
R32 SPEEDROD	51

### Couplings

Thread	Dia, mm	Length, mm	Part No.
T38	55	190	7314 3355 00
R38	55	170	7994 3655 00

**Atlas Copco**

9851 1966 01 c

The manufacturer reserves the right to make modifications without prior notice.